

Genie®

Operator's Manual

Third Edition
Second Printing
Part No. 82299



Load Lifter™

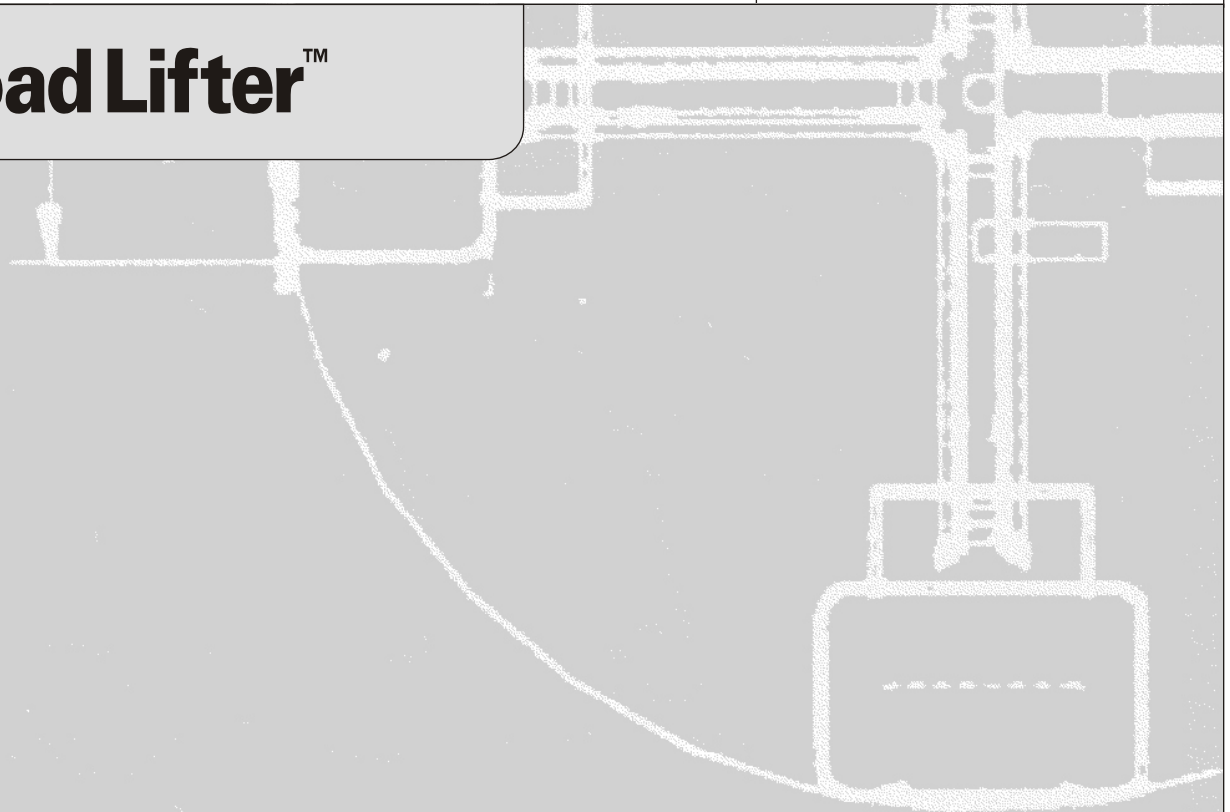

Important

Read, understand and obey these safety rules and operating instructions before operating this machine. Only trained and authorized personnel shall be permitted to operate this machine. If you have any questions, call Genie Industries.

Contents

	Page
Safety	1
Legend	5
Pre-operation Inspection	6
Function Tests	8
Workplace Inspection	10
Operating Instructions	11
Decals	13
Specifications	15

Contact us:

Internet: <http://www.genielift.com>
e-mail: techpub@genieind.com

Copyright © 1995 by Genie Industries

First Edition: Second Printing, July 1995
Second Edition: Third Printing, December 2001
Third Edition: Second Printing, January 2004

"Genie" is a registered trademark of Genie Industries in the U.S.A. and many other countries. "Load Lifter" is a trademark of Genie Industries.

 Printed on recycled paper

Printed in U.S.A.

Safety Rules



Warning

Failure to obey the instructions and safety rules in this manual may result in death or serious injury.

Do Not Operate Unless:

- You learn and practice the principles of safe machine operation contained in this operator's manual.
 - 1 Avoid hazardous situations.**
Know and understand the safety rules before going on to the next section.
 - 2 Always perform a pre-operation inspection.
 - 3 Always perform the function tests prior to use.
 - 4 Inspect the workplace.
 - 5 Only use the machine as it was intended.
- You read, understand and obey the manufacturer's instructions and safety rules—safety and operator's manuals and machine decals.
- You read, understand and obey employer's safety rules and worksite regulations.
- You read, understand and obey all applicable governmental regulations.
- You are properly trained to safely operate the machine.

SAFETY RULES

Fall Hazards

Do not use as a personnel lifting platform or step.

Do not stand or sit on the load platform.

Do not climb on the machine.



Do not place ladders or scaffolding against any part of the machine.

Prior to use, check the work area for drop-offs, holes, bumps, debris, unstable or slippery surfaces or other possible hazardous conditions.

Avoid debris and uneven surfaces while rolling a machine with the legs folded up.

Do not replace machine parts critical to stability or structure with items of different weight or specification.

Do not cause a horizontal force or side load to the machine by raising or lowering a fixed or overhanging load.

Do not use the machine on a moving or mobile surface or vehicle.

Tip-over Hazards

Do not exceed the rated load capacity. The maximum capacity is 200 lbs / 91 kg.

Do not raise the load unless the legs have been fully lowered and locked.

Do not raise the load unless the machine is on a firm, level surface.



Do not move the machine with a raised load, except for minor positioning.

Do not tilt the machine back with a raised load.

Do not operate the machine unless the wheel/leg configuration is properly installed.

Do not use blocks to level the machine.

Do not operate the machine in strong or gusty winds. Increasing the load surface area will decrease machine stability in windy conditions.

Collision Hazards

Do not raise if the load is not properly centered on the load platform.

Check the work area for overhead obstructions or other possible hazards.

Do not stand under or allow personnel under the machine when the load is raised.



Do not lower the load unless the area below is clear of personnel and obstructions.

Use common sense and planning when transporting the machine on an incline, slope or stairs.

SAFETY RULES

Lifting Hazard

Use proper lifting techniques to load or tip the machine, or to move the machine on stairs.

Electrocution Hazards

This machine is not electrically insulated and will not provide protection from contact with or proximity to electrical current.

Maintain safe distances away from electrical power lines and apparatus in accordance with applicable governmental regulations and the following chart.

Voltage	Minimum Safe Approach Distance	
	Feet	Meters
Phase to Phase		
0 to 300V	Avoid Contact	
300V to 50KV	10	3.1
50KV to 200KV	15	4.6
200KV to 350KV	20	6.1
350KV to 500KV	25	7.6
500KV to 750KV	35	10.7
750KV to 1000KV	45	13.7

Allow for mast movement and electrical line sway or sag, and beware of strong or gusty winds.

Keep away from the machine if it contacts energized power lines. Personnel must not touch or operate the machine until power lines are shut off.

Do not use the machine as a ground for welding.

Improper Use Hazard

Never leave a machine unattended with a load. Unauthorized personnel may attempt to operate the machine without proper instruction, creating an unsafe condition.

Bodily Injury Hazards

Do not grasp the cable.

Do not allow the platform to drop during setup.

Keep hands and fingers away from folding legs, pulleys, the carriage and other potential pinch points.

Do not place arms, hands or fingers through the frame.

Damaged Machine Hazards

Do not use a damaged or malfunctioning machine.



Do not use a machine with a worn, frayed, kinked or damaged cable.

Do not use a machine with less than 4 wraps of cable on the winch drum when the carriage is fully lowered.

Conduct a thorough pre-operation inspection prior to each use.

Be sure all decals are in place and legible.

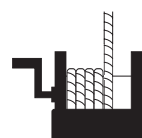

Maintain proper lubrication on the winch. Do not allow oil or grease on braking surfaces.

Do not use any type of lubrication on the channel surfaces.

Crushing Hazard

Maintain a firm grasp on the winch handle until the brake is locked. The brake is locked when the load will not cause the winch handle to turn.

SAFETY RULES

Decal Legend

Genie product decals use symbols, color coding and signal words to identify the following:



Safety alert symbol—used to alert personnel to potential personal injury hazards. Obey all safety messages that follow this symbol to avoid possible injury or death.

▲ DANGER

Red—used to indicate the presence of an imminently hazardous situation which, if not avoided, will result in death or serious injury.

▲ WARNING

Orange—used to indicate the presence of a potentially hazardous situation which, if not avoided, could result in death or serious injury.

▲ CAUTION

Yellow with safety alert symbol—used to indicate the presence of a potentially hazardous situation which, if not avoided, may cause minor or moderate injury.

CAUTION

Yellow without safety alert symbol—used to indicate the presence of a potentially hazardous situation which, if not avoided, may result in property damage.

NOTICE

Green—used to indicate operation or maintenance information.

Legend

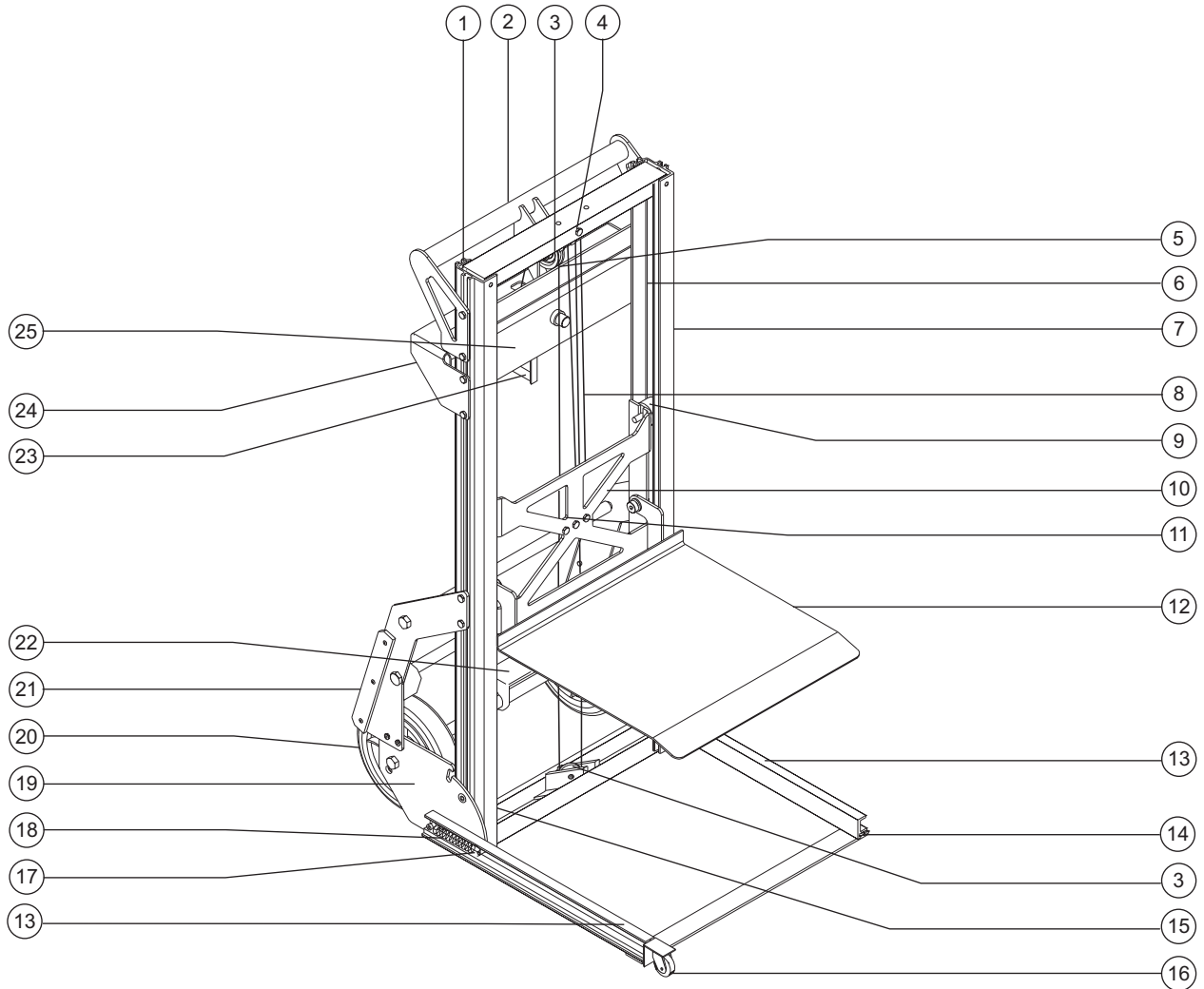

- | | | |
|----------------------------|------------------------------|-------------------------|
| 1 Outer frame glide button | 10 Carriage | 19 Base plate |
| 2 Handle | 11 Carriage pulley | 20 Rear wheel |
| 3 Inner frame pulley | 12 Load platform | 21 Stair glide (option) |
| 4 Cable termination | 13 Folding leg | 22 Brake (option) |
| 5 Outer frame pulley | 14 Footpad | 23 Winch handle |
| 6 Inner frame | 15 Inner frame glide button | 24 Winch (under plate) |
| 7 Outer frame | 16 Front leg caster (option) | 25 Winch mounting plate |
| 8 Cable | 17 Leg lock bolt | |
| 9 Roller wheel | 18 Leg spring | |

Pre-operation Inspection



Do Not Operate Unless:

- You learn and practice the principles of safe machine operation contained in this operator's manual.
 - 1 Avoid hazardous situations.
 - 2 Always perform a pre-operation inspection.**
Know and understand the pre-operation inspection before going on to the next section.
 - 3 Always perform function tests prior to use.
 - 4 Inspect the workplace.
 - 5 Only use the machine as it was intended.

Fundamentals

The pre-operation inspection is a visual inspection performed by the operator prior to each work shift. This inspection is designed to discover if anything is apparently wrong with a machine before the operator tests it.

Refer to the list on the next page and check each of the items.

If damage or any unauthorized variation from factory delivered condition is discovered, the machine must be tagged and removed from service.

Repairs to the machine may only be made by a qualified service technician, according to the manufacturer's specifications. After repairs are completed, the operator must perform a pre-operation inspection again before going on to the function tests.

PRE-OPERATION INSPECTION

Pre-operation Inspection

- Be sure that the operator's manual is complete, legible and available for reference.
- Be sure that all decals are legible and in place. See Decals section.

Check the following components or areas for damage, improperly installed or missing parts and unauthorized modifications:

- Winch and related components
- Base components
- Legs
- Glide buttons and roller wheels
- Inner and outer frames
- Cable anchor
- Cable and pulleys
- Wheels
- Casters (if equipped)
- Load platform
- Nuts, bolts and other fasteners
- Cable (kinks, frays, abrasions)

Check the entire machine for:

- Dents or damage
- Corrosion or oxidation
- Cracks in welds or structural components
- Be sure that all structural and other critical components are present and all associated fasteners and pins are in place and properly tightened.
- Be sure there is a minimum of 4 wraps of cable around the winch drum when the carriage is fully lowered.

Function Tests



Do Not Operate Unless:

- You learn and practice the principles of safe machine operation contained in this operator's manual.
 - 1 Avoid hazardous situations.
 - 2 Always perform a pre-operation inspection.
 - 3 Always perform function tests prior to use.**
- Know and understand the function tests before going on to the next section.**
- 4 Inspect the workplace.
 - 5 Only use the machine as it was intended.

Fundamentals

The function tests are designed to discover any malfunctions before the machine is put into service. The operator must follow the step-by-step instructions to test all machine functions.

A malfunctioning machine must never be used. If malfunctions are discovered, the machine must be tagged and removed from service. Repairs to the machine may only be made by a qualified service technician, according to the manufacturer's specifications.

After repairs are completed, the operator must perform a pre-operation inspection and function tests again before putting the machine into service.

FUNCTION TESTS

- 1 Select a test area that is firm, level and free of obstructions.

Setup

- 2 Tilt the machine back.
- 3 Lift the folding legs up to unlock them.
- 4 Lower the folding legs and push in to lock them.
- 5 Lower the platform. Do not drop it.
- 6 Remove the knob on the winch handle, reverse the winch handle and replace the knob. The handle grip should face the operator.

Test the Spring Tension of the Legs

- 7 Pull the legs out and release.
- ⦿ Result: The legs should snap back into locked position.

Test the Winch Operation

- 8 Rotate the winch handle clockwise to raise the platform.
- ⦿ Result: The carriage should raise to the top of the inner frame and then the inner frame should raise. The carriage and inner frame should move smoothly, free of hesitation and binding.
- 9 Rotate the winch handle counterclockwise to lower the platform.
- ⦿ Result: The inner frame and the carriage should lower into the outer frame. The carriage and inner frame should move smoothly, free of hesitation and binding.

Workplace Inspection



Do Not Operate Unless:

- You learn and practice the principles of safe machine operation contained in this operator's manual.
 - 1 Avoid hazardous situations.
 - 2 Always perform a pre-operation inspection.
 - 3 Always perform function tests prior to use.
 - 4 Inspect the workplace.**
Know and understand the workplace inspection before going on to the next section.
 - 5 Only use the machine as it was intended.

Be aware of and avoid the following hazardous situations:

- drop-offs or holes
- bumps and floor obstructions
- debris
- overhead obstructions and high voltage conductors
- hazardous locations
- sloped surfaces
- unstable or slippery surfaces
- inadequate surface support to withstand all load forces imposed by the machine
- wind and weather conditions
- all other possible unsafe conditions

Fundamentals

The workplace inspection helps the operator determine if the workplace is suitable for safe machine operation. It should be performed by the operator prior to moving the machine to the workplace.

It is the operator's responsibility to read and remember the workplace hazards, then watch for and avoid them while moving, setting up and operating the machine.

Operating Instructions



Do Not Operate Unless:

- You learn and practice the principles of safe machine operation contained in this operator's manual.
 - 1 Avoid hazardous situations.
 - 2 Always perform a pre-operation inspection.
 - 3 Always perform function tests prior to use.
 - 4 Inspect the workplace.
 - 5 Only use the machine as it was intended.**

Fundamentals

The Operating Instructions section provides instructions for each aspect of machine operation. It is the operator's responsibility to follow all the safety rules and instructions in the operator's manual.

Using the machine for anything other than lifting material is unsafe.

If more than one operator is expected to use a machine at different times in the same work shift, each operator is expected to follow all safety rules and instructions in the operator's manual. That means every new operator should perform a pre-operation inspection, function tests and a workplace inspection before using the machine.

Setup

Select an area that is firm, level and free of obstructions.

Follow the Setup procedures in the Function Tests section.

Raising and Lowering Load

- 1 Center the load on the load platform.
- 2 Raise the load by firmly grasping the winch handle and rotating it clockwise. Do not allow the cable to wind unevenly onto the drum.
- 3 Lower the load by firmly grasping the winch handle and rotating it counterclockwise. After lowering to the desired position, turn the winch handle clockwise (raise the load) $\frac{1}{4}$ turn to set the brake.

OPERATING INSTRUCTIONS

Moving Machine with a Load

It is best to move the machine on the worksite with no load. Moving a raised load should be restricted to positioning for loading and unloading. If it is necessary to move the machine with a raised load, understand and obey the following safety rules:

- Make sure the area is level and clear of obstructions.
- Make sure the load is centered on the load platform.
- Avoid sudden starts and stops.
- Travel with the load in the lowest possible position.
- Keep personnel away from the machine and load.
- Do not tilt the machine back with a raised load.

Moving Machine on Stairs

- Fully lower the load.
- Ease the machine over each stair. Maintain a firm grasp on the handle.
- Do not allow the machine to become unbalanced.
- Continue carefully up or down the stairs.
- Use the appropriate number of people and proper lifting techniques with heavy loads.

After Each Use

To prepare the machine for storage, follow the Setup procedure in reverse order. The platform must be fully lowered to store the legs.

Select a safe storage location - firm level surface, weather protected, clear of obstructions and traffic.

Decals

Inspection for Decals with Words

Determine whether the decals on your machine have words or symbols. Use the appropriate inspection to verify that all decals are legible and in place.

Part No.	Description	Quantity
33468	Warning - No Riders	1
35546	Warning - Machine Safety	1
35547	Notice - Machine Setup	1
35552	Warning - Tip-over	2
35555	Notice - Maximum Capacity, 200 lbs / 91 kg	1

Part No.	Description	Quantity
35567	Warning - Bodily Injury Hazard	1
52981	Cosmetic - Genie Load Lifter	1
44754	Label - Raise / Lower	1
97529	Caution - Bodily Injury Hazard	1

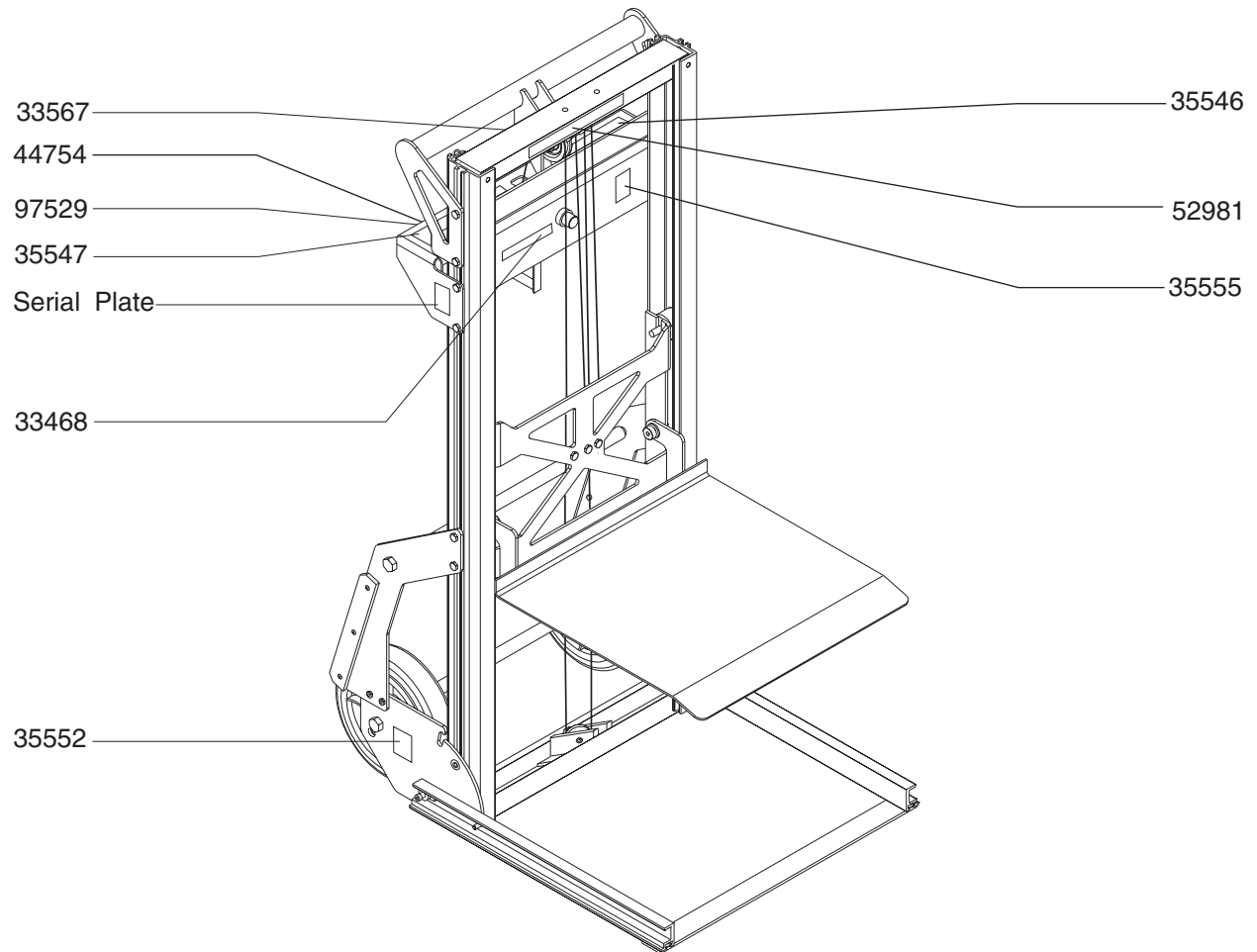

DECALS

Inspection for Decals with Symbols

Determine whether the decals on your machine have words or symbols. Use the appropriate inspection to verify that all decals are legible and in place.

Part No.	Description	Quantity
52981	Cosmetic - Genie Load Lifter	1
82487	Label - Read the Manual	1
82961	Label - Raise / Lower	1
82962	Warning - No Riders	1

Part No.	Description	Quantity
97514	Notice - Maximum Capacity, 91 kg	1
97532	Warning - Bodily Injury Hazard	1
97536	Warning - Do Not Reach	1

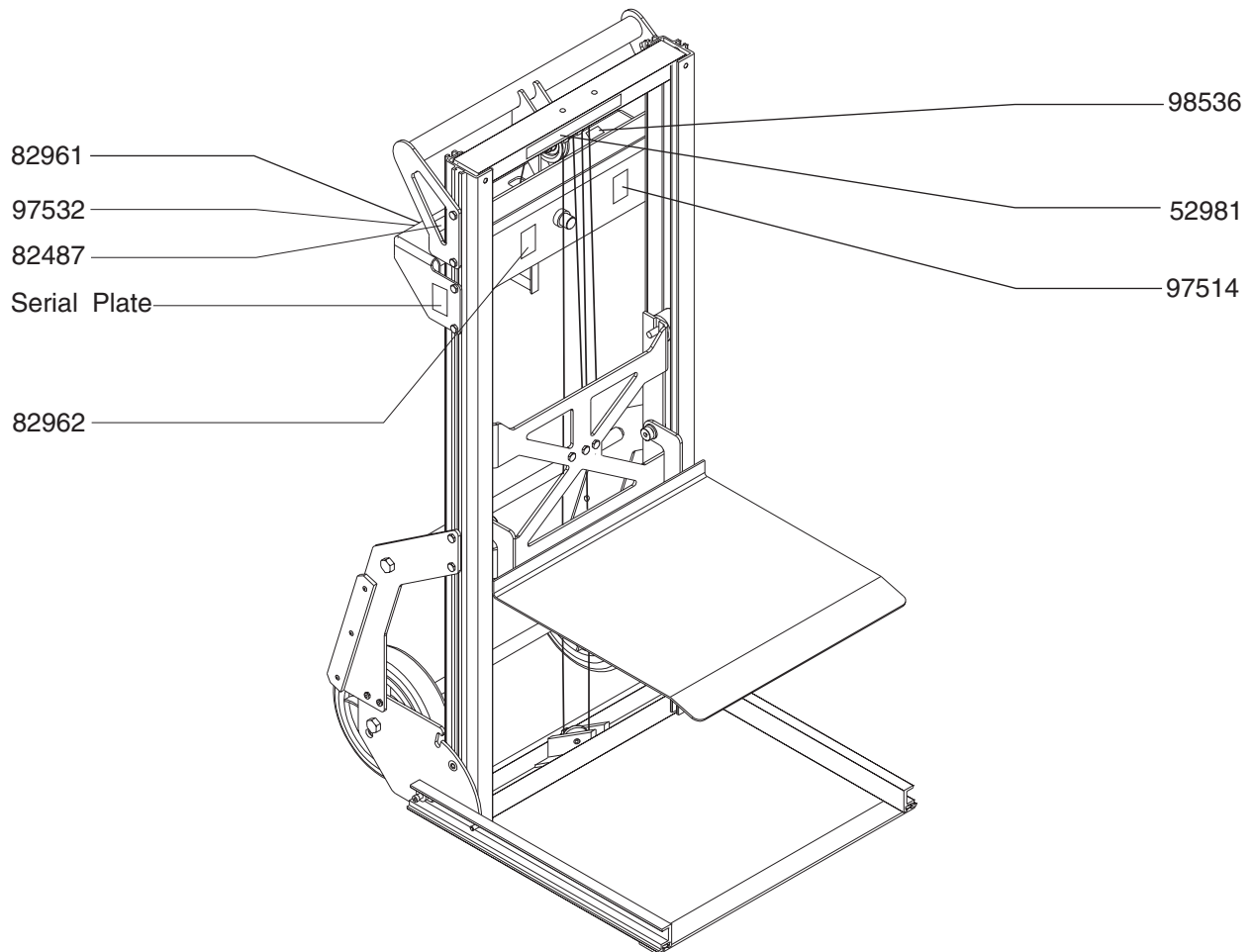

Specifications

Height, maximum platform	5 ft 7 in	1.70 m
Lift capacity	200 lbs	91 kg
Machine weight	44 ¹ / ₂ lbs	20 kg
Height, stowed	45 in	1.14 m
Width	20 ¹ / ₂ in	52 cm
Airborne Noise Emissions by Machinery	78 dB	
Maximum sound level at normal operating workstations (A-weighted)		

Length - Stowed	15 in	38 cm
Length - Operating	28 ³ / ₄ in	73 cm
Load Platform		
Length	17 in	43.2 cm
Width	16 ³ / ₄ in	43 cm
Load Height	2 in	5 cm

Component Mounting Locations

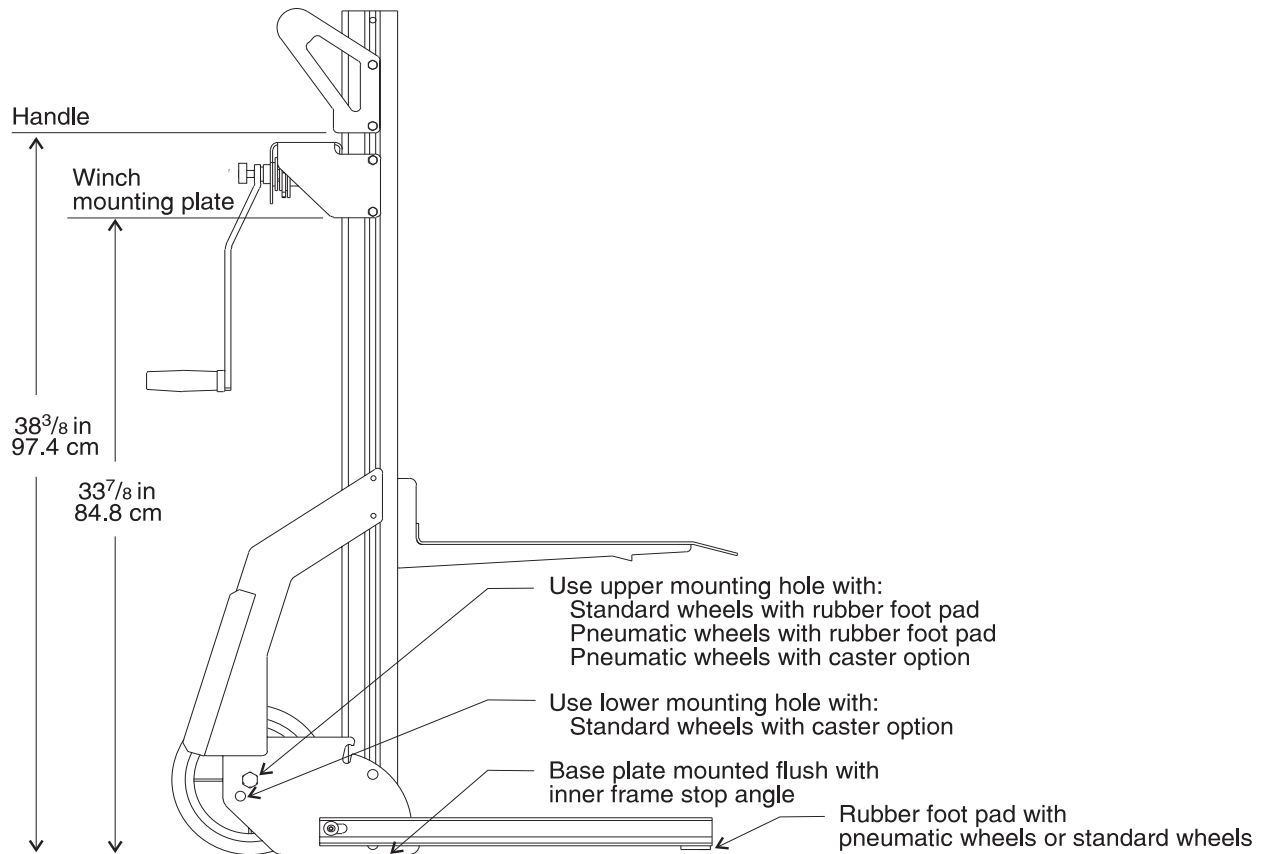

Genie Scandinavia
Phone +46 31 3409612
Fax +46 31 3409613

Genie France
Phone +33 (0)2 37 26 09 99
Fax +33 (0)2 37 26 09 98

Genie Iberica
Phone +34 93 579 5042
Fax +34 93 579 5059

Genie Germany
Phone +49 (0)4202 88520
Fax +49 (0)4202 8852-20

Genie U.K.
Phone +44 (0)1476 584333
Fax +44 (0)1476 584334

Genie Mexico City
Phone +52 55 5666 5242
Fax +52 55 5666 3241

Genie North America
Phone 425.881.1800
Toll Free USA and Canada
800.536.1800
Fax 425.883.3475

Genie Australia Pty Ltd.
Phone +61 7 3375 1660
Fax +61 7 3375 1002

Genie China
Phone +86 21 53852570
Fax +86 21 53852569

Genie Malaysia
Phone +65 98 480 775
Fax +65 67 533 544

Genie Japan
Phone +81 3 3453 6082
Fax +81 3 3453 6083

Genie Korea
Phone +82 25 587 267
Fax +82 25 583 910

Genie Brasil
Phone +55 11 41 665 755
Fax +55 11 41 665 754

Genie Holland
Phone +31 10 220 7911
Fax +31 10 220 6642

Distributed By: